

# Specifications

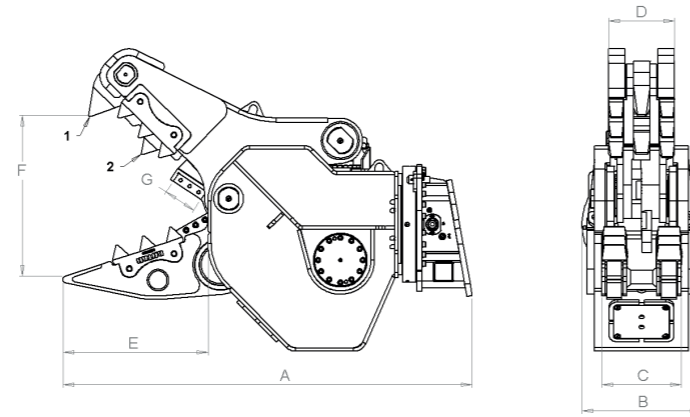

Ingenious, reliable, service-friendly and maximal productivity.  
That is the power of Rotar!

Type RDP	20 S	25 S	32 S	42 S
<b>Information</b>				
Machine class (t)	15 - 25	22- 35	32 - 50	45 - 70
Weight (kg)*	2100	2765	3100	4500
Cyclus open/close (s.)	1,9 - 1,2	2,2 - 2,4	2,5 - 2,8	2,6 - 2,8
Closing force at position 1 (t)	62	70	95	105
Closing force at position 2 (t)	100	107	152	195
<b>Dimensions</b>				
Dimension A (mm)	2100	2270	2458	2640
Dimension B (mm)	760	760	760	880
Dimension C (mm)	390	479	495	556
Dimension D (mm)	310	350	398	470
Dimension E (mm)	750	822	867	930
Dimension F (mm)	900	1040	1090	1290
Dimension G (mm)	200	200	200	250
<b>Attachement</b>				
Rotar Hole-pattern	140 - 150	140 - 150	140 - 150	150
<b>Hydraulic</b>				
Max. operating pressure cylinder (bar)	350	350	350	350
Oil volume cylinder (L/min)	150 - 250	150 - 250	250 - 300	250 - 300
Max operating pressure motor (bar)	170	170	170	170
Oil volume motor (L/min)	40 - 60	40 - 60	40 - 60	40 - 60

\* Weight exclusive adapterplate with bracket.

\*\* Figures given for cycle times and cutting forces are indications only. External factors such as excavator setting, hydraulic infrastructure, quickcouplers and fittings may influence performance.

\*\*\* Technical specifications are subject to change without prior notice.



## RDP-Series

### Rotar International BV

Address Sisalstraat 85, 8281 JK Genemuiden (NL)

Tel. +31(0) 38 385 54 71

Fax +31(0) 38 385 54 02

E-mail [info@rotar.com](mailto:info@rotar.com)

Website [www.rotar.com](http://www.rotar.com)



# RDP

## Rotar Demolition Pulverizer

Incredible crushing power combined with tremendous cutting power makes the Rotar Demolition Pulverizer the perfect pulverizer for both primary and secondary demolitions. The RDP will work its way through any concrete construction with easily replaceable wear parts.



### Replaceable teeth

The RDP Series is fitted with replaceable casting teeth. The design of the teeth guarantees powerful penetration. It is an impressive sight to see these teeth cutting through extremely strong concrete constructions. The RDP's body is assembled from high-grade and wear-resistant materials, making it extremely strong.

### Upper head and slewing ring

The RDP Series is fitted with a strong rotating upper head and a heavy-duty slewing ring. The hydraulic motors in the upper head generate a high torque, suited for heavy loading in any position.



### Specially developed speed valve

The speed valve developed by Rotar allows the jaws to close quickly and automatically switch from speed to power mode as soon as the job requires more cutting power.

### Trunnion hydraulic cylinder

The construction of the hydraulic cylinder ensures optimum efficiency of the cutting power and a compact design with a favorable center of gravity. The large diameter of hoses, bores, and pipes reduces the back pressure in the hydraulic system and contributes to the extraordinary features of this RDP.



GET THE  
RED CRUSH!