



HYDRAULIC ROCK BREAKER

SD6



NEW KEY ASSET
FOR ALL JOBSITES

DESIGNED FOR 700 KG
TO 1.2 TONS CARRIERS

POWERFUL,
SAFE AND COMPACT

LANDSCAPING, DEMOLITION,
TRENCHING, CIVIL ENGINEERING,
INSIDE AND OUTSIDE:
VERSATILE AND EFFICIENT

BENEFITS

- **Hydraulic accumulator:** no more regular nitrogen controls and recharges on jobsites.
- **Tie rod free:** less weight and cost, more power and reliability.
- **Made in France:** superior quality steel and manufacturing excellence.
- **Improved soundproofing :** lower noise levels for urban jobsites.
- **Easy handling:** two lifting points to handle the breaker with perfect balance and safety, also acting as hoses protection.
- **Tool changing:** new user friendly, simple, safe and reliable system, with one single retainer.



HYDRAULIC ROCK BREAKER

NEW KEY ASSET FOR ALL JOBSITES

WEIGHT & DIMENSIONS

WEIGHT (KG/LB)

BREAKER	55	120
+ MOUNTED TOOL	58.7	128
+ MOUNTED ADAPTER PLATE (MAX)	73	161

DIMENSIONS (MM/IN)

A	865	34
B	200	8
C	281	11
D	595	23
E	147	6
F	172	7
G	24	0.94

OPERATING INFORMATION

CARRIER WEIGHT RANGE (MIN-MAX, MT)	0.7 - 1.2	
OIL FLOW (MIN-MAX, L/MIN / GPM)	12 - 23	3.2 - 6
OPERATING PRESSURE (MAX, BAR/PSI)	110	1,600
BACK PRESSURE (MAX, BAR/PSI)	20	290
INPUT POWER (KW)	4.2	
STRIKING FREQUENCY (MIN-MAX, BPM)	725 - 1,460	
NOISE LEVEL /10M (DBA)	87	
SOUNDPROOFING	standard	
HOSE PROTECTION	standard	

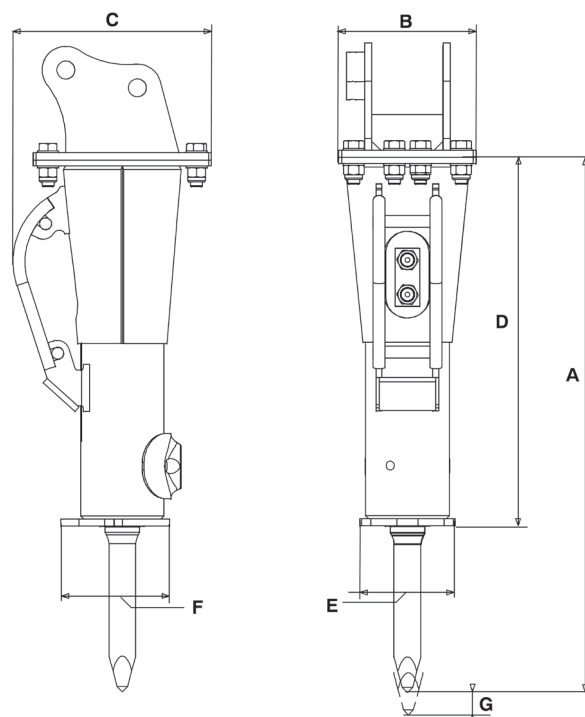

OPTIONS

PART NUMBER

ADAPTER PLATE	upon request
SPECIAL PAINTING	upon request

CONSUMABLES

PART NUMBER

GREASE CARTRIDGES (X48)	86799152
-------------------------	----------

MAINTENANCE KITS

PART NUMBER

LEVEL 1	86651056
LEVEL 2	101112768
LEVEL 3 (+2 WARRANTY YEARS*)	101112769

TOOLS

DIAMETER (MM/IN)	37 / 1.45	37 / 1.45
LENGTH (MM/IN)	438 / 17.2	438 / 17.2
WEIGHT (KG/LB)	3.7 / 8	3.37 / 7.42
PART NUMBER	86646106	86646114



The content of this brochure constitutes non-binding information and may be changed at any time without notice. Montabert gives, and the brochure contains, no warranties whatsoever, express or implied. All the contents, including but not limited to text, images, graphics are all subject to copyright and all intellectual property protection. Their use or misuse is strictly prohibited. Montabert brand and logo used herein are the property of Montabert. Nothing contained on this document shall be construed as constituting any commitment by Montabert or as granting any license or right to use any intellectual property. ©2024 Montabert. All rights reserved.

montabert.com

*see warranty conditions





HYDRAULIC ROCK BREAKER

SD8



NEW KEY ASSET
FOR ALL JOBSITES

DESIGNED FOR 1 TO
1.7 TONS CARRIERS

POWERFUL,
SAFE AND COMPACT

LANDSCAPING, DEMOLITION,
TRENCHING, CIVIL ENGINEERING,
INSIDE AND OUTSIDE:
VERSATILE AND EFFICIENT

BENEFITS

- **Hydraulic accumulator:** no more regular nitrogen controls and recharges on jobsites.
- **Tie rod free:** less weight and cost, more power and reliability.
- **Made in France:** superior quality steel and manufacturing excellence.
- **Improved soundproofing :** lower noise levels for urban jobsites.
- **Easy handling:** two lifting points to handle the breaker with perfect balance and safety, also acting as hoses protection.
- **Tool changing:** new user friendly, simple, safe and reliable system, with one single retainer.



HYDRAULIC ROCK BREAKER

NEW KEY ASSET FOR ALL JOBSITES

WEIGHT & DIMENSIONS

WEIGHT (KG/LB)

BREAKER	71	156
+ MOUNTED TOOL	76.4	168
+ MOUNTED ADAPTER PLATE (MAX)	112	247

DIMENSIONS (MM/IN)

A	898	35
B	230	9
C	334	13
D	618	24
E	159	6.25
F	183	7.20
G	25	0.98

OPERATING INFORMATION

CARRIER WEIGHT RANGE (MIN-MAX, MT)	1 - 1.7	
OIL FLOW (MIN-MAX, L/MIN / GPM)	15 - 30	4 - 8
OPERATING PRESSURE (MAX, BAR/PSI)	120	1,740
BACK PRESSURE (MAX, BAR/PSI)	35	507
INPUT POWER (KW)	6	
STRIKING FREQUENCY (MIN-MAX, BPM)	800 - 1,600	
NOISE LEVEL /10M (DBA)	90	
SOUNDPROOFING	standard	
HOSE PROTECTION	standard	

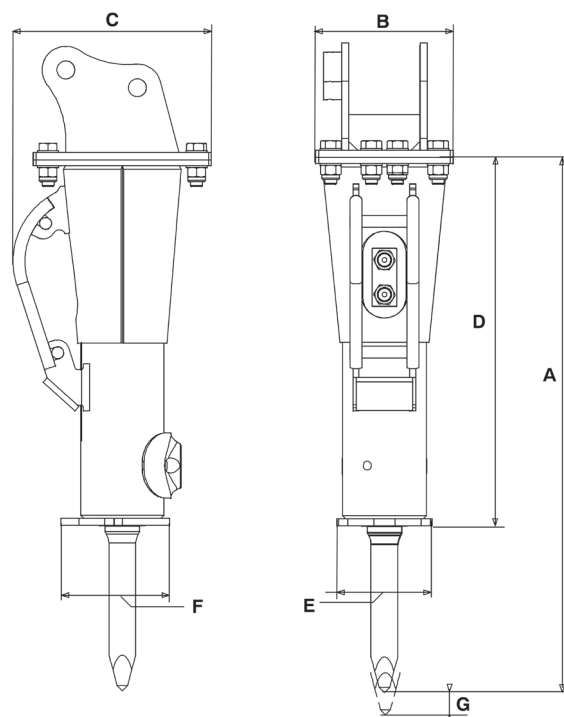

OPTIONS

PART NUMBER

ADAPTER PLATE	upon request
SPECIAL PAINTING	upon request

CONSUMABLES

PART NUMBER

GREASE CARTRIDGES (X48)	86799152
-------------------------	----------

MAINTENANCE KITS

PART NUMBER

LEVEL 1	86638947
LEVEL 2	101112771
LEVEL 3 (+2 WARRANTY YEARS*)	101112772

TOOLS

DIAMETER (MM/IN)	45 / 1.77	45 / 1.77	45 / 1.77
LENGTH (MM/IN)	455 / 17.9	455 / 17.9	455 / 17.9
WEIGHT (KG/LB)	5.1 / 11	5.2 / 11.46	5.4 / 12
PART NUMBER	86631918	86631900	86638566



The content of this brochure constitutes non-binding information and may be changed at any time without notice. Montabert gives, and the brochure contains, no warranties whatsoever, express or implied. All the contents, including but not limited to text, images, graphics are all subject to copyright and all intellectual property protection. Their use or misuse is strictly prohibited. Montabert brand and logo used herein are the property of Montabert. Nothing contained on this document shall be construed as constituting any commitment by Montabert or as granting any license or right to use any intellectual property. ©2024 Montabert. All rights reserved.

montabert.com

*see warranty conditions





HYDRAULIC ROCK BREAKER

SD12



NEW KEY ASSET
FOR ALL JOBSITES

DESIGNED FOR 1.2 TO
2.2 TONS CARRIERS

POWERFUL,
SAFE AND COMPACT

LANDSCAPING, DEMOLITION,
TRENCHING, CIVIL ENGINEERING,
INSIDE AND OUTSIDE:
VERSATILE AND EFFICIENT

BENEFITS

- **Hydraulic accumulator:** no more regular nitrogen controls and recharges on jobsites.
- **Tie rod free:** less weight and cost, more power and reliability.
- **Made in France:** superior quality steel and manufacturing excellence.
- **Improved soundproofing :** lower noise levels for urban jobsites.
- **Easy handling:** two lifting points to handle the breaker with perfect balance and safety, also acting as hoses protection.
- **Tool changing:** new user friendly, simple, safe and reliable system, with one single retainer.



HYDRAULIC ROCK BREAKER

NEW KEY ASSET FOR ALL JOBSITES

WEIGHT & DIMENSIONS

WEIGHT (KG/LB)

BREAKER	91	201
+ MOUNTED TOOL	97	214
+ MOUNTED ADAPTER PLATE (MAX)	133	293

DIMENSIONS (MM/IN)

A	926	36
B	230	9
C	346	14
D	637	25
E	166	7
F	190	7.48
G	34	1.33

OPERATING INFORMATION

CARRIER WEIGHT RANGE (MIN-MAX, MT)	1.2 - 2.2
OIL FLOW (MIN-MAX, L/MIN / GPM)	17 - 35 / 4.5 - 9
OPERATING PRESSURE (MAX, BAR/PSI)	120 / 1,740
BACK PRESSURE (MAX, BAR/PSI)	32 / 465
INPUT POWER (KW)	7
STRIKING FREQUENCY (MIN-MAX, BPM)	825 - 1,700
NOISE LEVEL /10M (DBA)	89
SOUNDPROOFING	standard
HOSE PROTECTION	standard

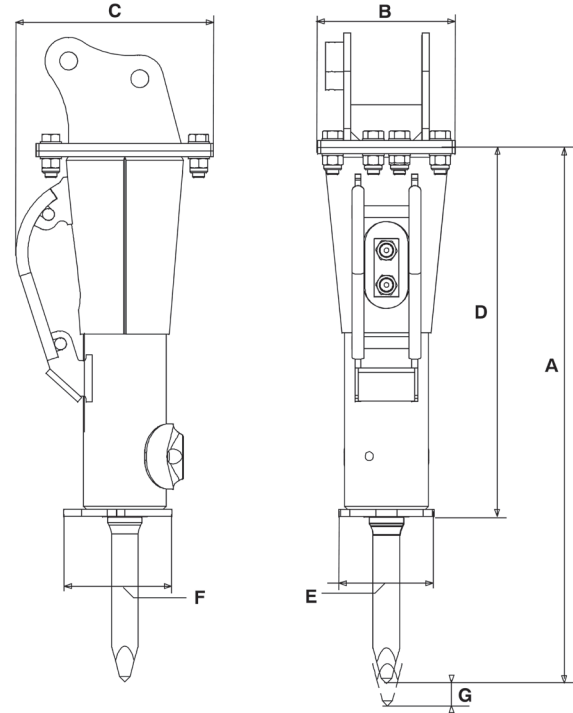

OPTIONS

OPTIONS	PART NUMBER
ADAPTER PLATE	upon request
SPECIAL PAINTING	upon request

CONSUMABLES

GREASE CARTRIDGES (X48)

PART NUMBER

86799152

MAINTENANCE KITS

LEVEL	PART NUMBER
LEVEL 1	86638954
LEVEL 2	101112774
LEVEL 3 (+2 WARRANTY YEARS*)	101112775

TOOLS

TOOLS		
DIAMETER (MM/IN)	47 / 1.85	47 / 1.85
LENGTH (MM/IN)	475 / 18.7	475 / 18.7
WEIGHT (KG/LB)	5.8 / 12.7	6 / 13
PART NUMBER	86621216	86620739



The content of this brochure constitutes non-binding information and may be changed at any time without notice. Montabert gives, and the brochure contains, no warranties whatsoever, express or implied. All the contents, including but not limited to text, images, graphics are all subject to copyright and all intellectual property protection. Their use or misuse is strictly prohibited. Montabert brand and logo used herein are the property of Montabert. Nothing contained on this document shall be construed as constituting any commitment by Montabert or as granting any license or right to use any intellectual property. ©2024 Montabert. All rights reserved.

montabert.com

*see warranty conditions





HYDRAULIC ROCK BREAKER

SD16



NEW KEY ASSET
FOR ALL JOBSITES

DESIGNED FOR 1.5 TO
3.7 TONS CARRIERS

POWERFUL,
SAFE AND COMPACT

LANDSCAPING, DEMOLITION,
TRENCHING, CIVIL ENGINEERING,
INSIDE AND OUTSIDE:
VERSATILE AND EFFICIENT

BENEFITS

- **Hydraulic accumulator:** no more regular nitrogen controls and recharges on jobsites.
- **Tie rod free:** less weight and cost, more power and reliability.
- **Made in France:** superior quality steel and manufacturing excellence.
- **Improved soundproofing :** lower noise levels for urban jobsites.
- **Easy handling:** two lifting points to handle the breaker with perfect balance and safety, also acting as hoses protection.
- **Tool changing:** new user friendly, simple, safe and reliable system, with one single retainer.



HYDRAULIC ROCK BREAKER

NEW KEY ASSET FOR ALL JOBSITES

WEIGHT & DIMENSIONS

WEIGHT (KG/LB)

BREAKER	121	266
+ MOUNTED TOOL	131	288
+ MOUNTED ADAPTER PLATE (MAX)	194	428

DIMENSIONS (MM/IN)

A	1,036	41
B	280	11
C	427	17
D	701	28
E	186	7.32
F	205	8.07
G	34	1.33

OPERATING INFORMATION

CARRIER WEIGHT RANGE (MIN-MAX, MT)	1.5 - 3.7
OIL FLOW (MIN-MAX, L/MIN / GPM)	25 - 50 / 6.6 - 13
OPERATING PRESSURE (MAX, BAR/PSI)	120 / 1,740
BACK PRESSURE (MAX, BAR/PSI)	32 / 465
INPUT POWER (KW)	10
STRIKING FREQUENCY (MIN-MAX, BPM)	770 - 1,550
NOISE LEVEL /10M (DBA)	91
SOUNDPROOFING	standard
HOSE PROTECTION	standard

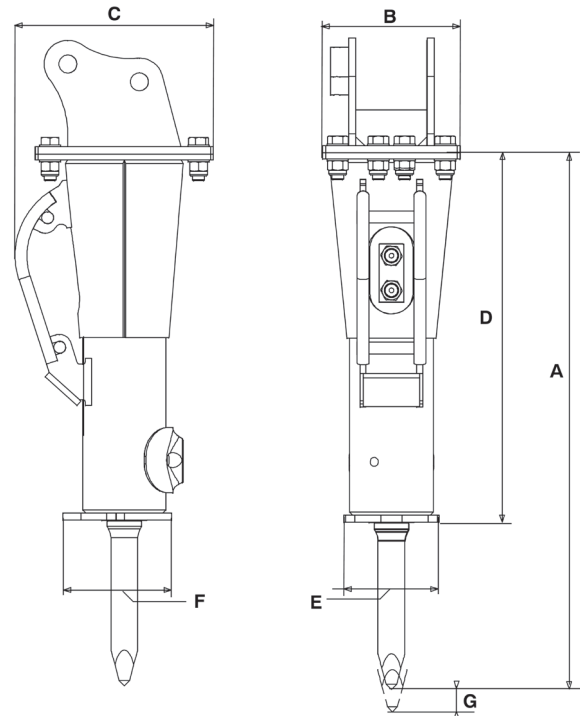

OPTIONS

OPTIONS	PART NUMBER
ADAPTER PLATE	upon request
SPECIAL PAINTING	upon request

CONSUMABLES

GREASE CARTRIDGES (X48)

PART NUMBER

86799152

MAINTENANCE KITS

LEVEL	PART NUMBER
LEVEL 1	86638962
LEVEL 2	101112777
LEVEL 3 (+2 WARRANTY YEARS*)	101112779

TOOLS

TOOLS		
DIAMETER (MM/IN)	55 / 2.16	55 / 2.16
LENGTH (MM/IN)	550 / 21.6	550 / 21.6
WEIGHT (KG/LB)	9.7 / 21	10 / 22
PART NUMBER	86625688	86625670



The content of this brochure constitutes non-binding information and may be changed at any time without notice. Montabert gives, and the brochure contains, no warranties whatsoever, express or implied. All the contents, including but not limited to text, images, graphics are all subject to copyright and all intellectual property protection. Their use or misuse is strictly prohibited. Montabert brand and logo used herein are the property of Montabert. Nothing contained on this document shall be construed as constituting any commitment by Montabert or as granting any license or right to use any intellectual property. ©2024 Montabert. All rights reserved.

montabert.com

*see warranty conditions





HYDRAULIC ROCK BREAKER

SD22



NEW KEY ASSET
FOR ALL JOBSITES

DESIGNED FOR 2.5 TO
5.3 TONS CARRIERS

POWERFUL,
SAFE AND COMPACT

LANDSCAPING, DEMOLITION,
TRENCHING, CIVIL ENGINEERING,
INSIDE AND OUTSIDE:
VERSATILE AND EFFICIENT

BENEFITS

- **Hydraulic accumulator:** no more regular nitrogen controls and recharges on jobsites.
- **Tie rod free:** less weight and cost, more power and reliability.
- **Made in France:** superior quality steel and manufacturing excellence.
- **Improved soundproofing :** lower noise levels for urban jobsites.
- **Easy handling:** two lifting points to handle the breaker with perfect balance and safety, also acting as hoses protection.
- **Tool changing:** new user friendly, simple, safe and reliable system, with one single retainer.



HYDRAULIC ROCK BREAKER

NEW KEY ASSET FOR ALL JOBSITES

WEIGHT & DIMENSIONS

WEIGHT (KG/LB)

BREAKER	184	405
+ MOUNTED TOOL	200	440
+ MOUNTED ADAPTER PLATE (MAX)	286	631

DIMENSIONS (MM/IN)

A	1,182	47
B	320	13
C	466	18.3
D	812	31.9
E	214	8.42
F	240	9.44
G	45	1.77

OPERATING INFORMATION

CARRIER WEIGHT RANGE (MIN-MAX, MT)	2.5 - 5.3
OIL FLOW (MIN-MAX, L/MIN / GPM)	30 - 65 / 7.9 - 17
OPERATING PRESSURE (MAX, BAR/PSI)	120 / 1,740
BACK PRESSURE (MAX, BAR/PSI)	30 / 435
INPUT POWER (KW)	13
STRIKING FREQUENCY (MIN-MAX, BPM)	600 - 1,360
NOISE LEVEL /10M (DBA)	89
SOUNDPROOFING	standard
HOSE PROTECTION	standard

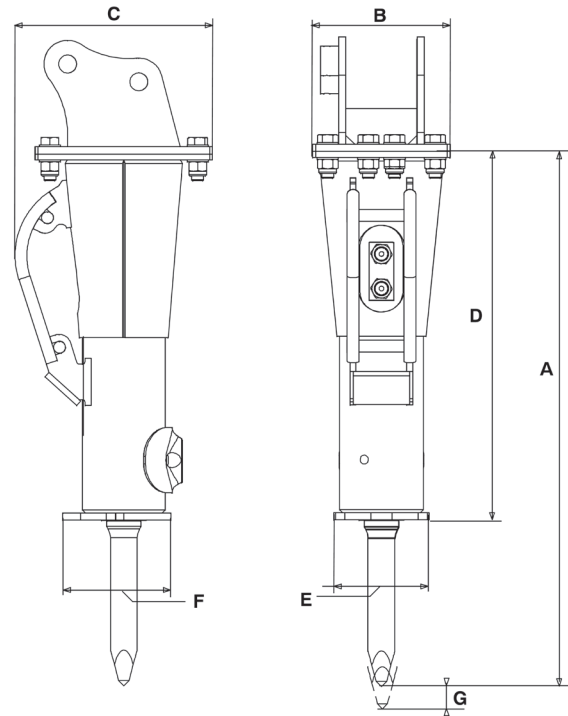

OPTIONS

OPTIONS	PART NUMBER
ADAPTER PLATE	upon request
SPECIAL PAINTING	upon request

CONSUMABLES

GREASE CARTRIDGES (X48)

PART NUMBER

86799152

MAINTENANCE KITS

LEVEL	PART NUMBER
LEVEL 1	101112784
LEVEL 2	101112785
LEVEL 3 (+2 WARRANTY YEARS*)	101112786

TOOLS

TOOLS		
DIAMETER (MM/IN)	65 / 2.55	65 / 2.55
LENGTH (MM/IN)	618 / 24	618 / 24
WEIGHT (KG/LB)	14.8 / 33	15.2 / 34
PART NUMBER	86636370	86636362



The content of this brochure constitutes non-binding information and may be changed at any time without notice. Montabert gives, and the brochure contains, no warranties whatsoever, express or implied. All the contents, including but not limited to text, images, graphics are all subject to copyright and all intellectual property protection. Their use or misuse is strictly prohibited. Montabert brand and logo used herein are the property of Montabert. Nothing contained on this document shall be construed as constituting any commitment by Montabert or as granting any license or right to use any intellectual property. ©2024 Montabert. All rights reserved.

montabert.com

*see warranty conditions





HYDRAULIC ROCK BREAKER

SD28



NEW KEY ASSET
FOR ALL JOBSITES

DESIGNED FOR 3 TO
7.5 TONS CARRIERS

POWERFUL,
SAFE AND COMPACT

LANDSCAPING, DEMOLITION,
TRENCHING, CIVIL ENGINEERING,
INSIDE AND OUTSIDE:
VERSATILE AND EFFICIENT

BENEFITS

- **Hydraulic accumulator:** no more regular nitrogen controls and recharges on jobsites.
- **Tie rod free:** less weight and cost, more power and reliability.
- **Made in France:** superior quality steel and manufacturing excellence.
- **Improved soundproofing :** lower noise levels for urban jobsites.
- **Easy handling:** two lifting points to handle the breaker with perfect balance and safety, also acting as hoses protection.
- **Tool changing:** new user friendly, simple, safe and reliable system, with one single retainer.



HYDRAULIC ROCK BREAKER

NEW KEY ASSET FOR ALL JOBSITES

WEIGHT & DIMENSIONS

WEIGHT (KG/LB)

BREAKER	204	451
+ MOUNTED TOOL	231.1	511
+ MOUNTED ADAPTER PLATE (MAX)	318	701

DIMENSIONS (MM/IN)

A	1,221	48
B	320	13
C	472	19
D	863	33.9
E	223	8.77
F	250	9.84
G	46	1.81

OPERATING INFORMATION

CARRIER WEIGHT RANGE (MIN-MAX, MT)	3 - 7.5	
OIL FLOW (MIN-MAX, L/MIN / GPM)	40 - 75	10.5 - 20
OPERATING PRESSURE (MAX, BAR/PSI)	120	1,740
BACK PRESSURE (MAX, BAR/PSI)	30	435
INPUT POWER (KW)	13	
STRIKING FREQUENCY (MIN-MAX, BPM)	630 - 1,420	
NOISE LEVEL /10M (DBA)	94	
SOUNDPROOFING	standard	
HOSE PROTECTION	standard	

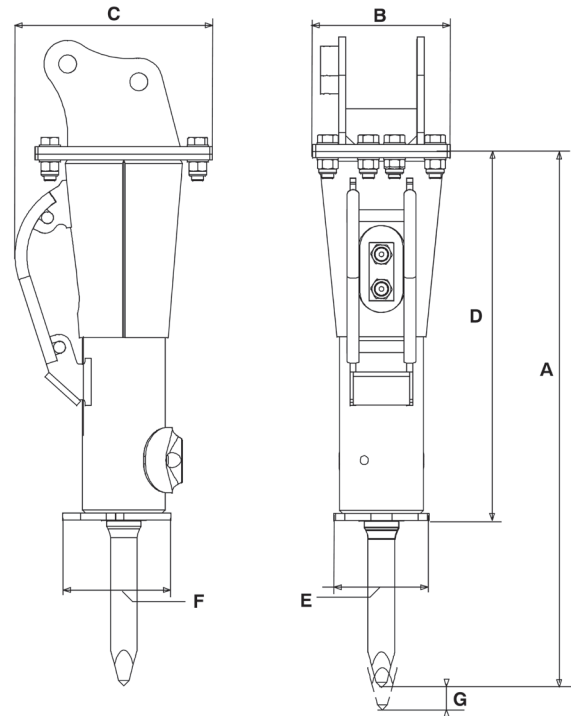

OPTIONS

OPTIONS	PART NUMBER
ADAPTER PLATE	upon request
SPECIAL PAINTING	upon request

CONSUMABLES

GREASE CARTRIDGES (X48)

PART NUMBER

86799152

MAINTENANCE KITS

LEVEL	PART NUMBER
LEVEL 1	101112788
LEVEL 2	101112789
LEVEL 3 (+2 WARRANTY YEARS*)	101112790

TOOLS

TOOLS		
DIAMETER (MM/IN)	72 / 2.8	72 / 2.8
LENGTH (MM/IN)	662 / 26	662 / 26
WEIGHT (KG/LB)	19.4 / 43	27.1 / 60
PART NUMBER	86636396	86636388



The content of this brochure constitutes non-binding information and may be changed at any time without notice. Montabert gives, and the brochure contains, no warranties whatsoever, express or implied. All the contents, including but not limited to text, images, graphics are all subject to copyright and all intellectual property protection. Their use or misuse is strictly prohibited. Montabert brand and logo used herein are the property of Montabert. Nothing contained on this document shall be construed as constituting any commitment by Montabert or as granting any license or right to use any intellectual property. ©2024 Montabert. All rights reserved.

montabert.com

*see warranty conditions





HYDRAULIC ROCK BREAKER

SD36



NEW KEY ASSET
FOR ALL JOBSITES

DESIGNED FOR 4 TO
10 TONS CARRIERS

POWERFUL,
SAFE AND COMPACT

LANDSCAPING, DEMOLITION,
TRENCHING, CIVIL ENGINEERING,
INSIDE AND OUTSIDE:
VERSATILE AND EFFICIENT

BENEFITS

- **Hydraulic accumulator:** no more regular nitrogen controls and recharges on jobsites.
- **Tie rod free:** less weight and cost, more power and reliability.
- **Made in France:** superior quality steel and manufacturing excellence.
- **Improved soundproofing :** lower noise levels for urban jobsites.
- **Easy handling:** two lifting points to handle the breaker with perfect balance and safety, also acting as hoses protection.
- **Tool changing:** new user friendly, simple, safe and reliable system, with one single retainer.



HYDRAULIC ROCK BREAKER

NEW KEY ASSET FOR ALL JOBSITES

WEIGHT & DIMENSIONS

WEIGHT (KG/LB)

BREAKER	279	616
+ MOUNTED TOOL	304	671
+ MOUNTED ADAPTER PLATE (MAX)	396	873

DIMENSIONS (MM/IN)

A	1,374	54
B	432	17
C	535	21
D	978	39
E	240	9.44
F	270	11
G	47.5	1.87

OPERATING INFORMATION

CARRIER WEIGHT RANGE (MIN-MAX, MT)	4 - 10
OIL FLOW (MIN-MAX, L/MIN / GPM)	55 - 100 / 14.5 - 26.5
OPERATING PRESSURE (MAX, BAR/PSI)	125 / 1,815
BACK PRESSURE (MAX, BAR/PSI)	20 / 290
INPUT POWER (KW)	20.8
STRIKING FREQUENCY (MIN-MAX, BPM)	700 - 1,540
NOISE LEVEL /10M (DBA)	93
SOUNDPROOFING	standard
HOSE PROTECTION	standard

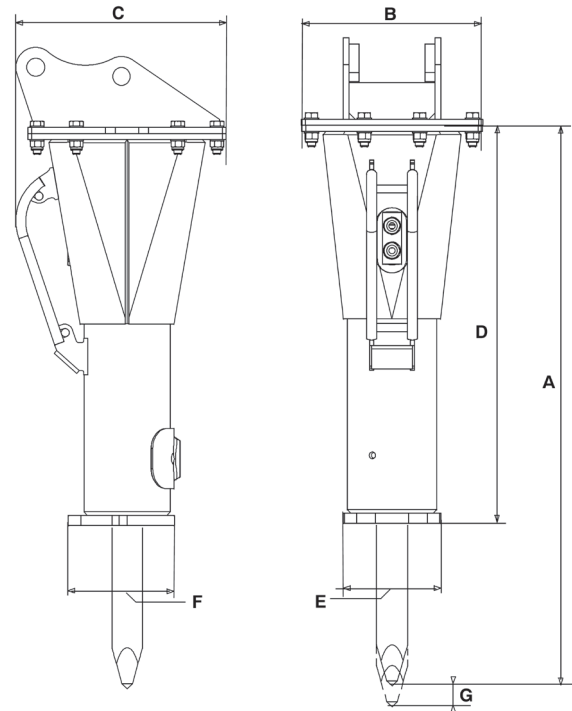

OPTIONS

PART NUMBER

ADAPTER PLATE	upon request
SPECIAL PAINTING	upon request

CONSUMABLES

PART NUMBER

GREASE CARTRIDGES (X48)	86799152
-------------------------	----------

MAINTENANCE KITS

PART NUMBER

LEVEL 1	86639960
LEVEL 2	101112794
LEVEL 3 (+2 WARRANTY YEARS*)	101112795

TOOLS

DIAMETER (MM/IN)	76 / 2.99	76 / 2.99	76 / 2.99
LENGTH (MM/IN)	709 / 27.9	709 / 27.9	709 / 27.9
WEIGHT (KG/LB)	23 / 51	24 / 53	25 / 55
PART NUMBER	86639226	86639218	86641438



The content of this brochure constitutes non-binding information and may be changed at any time without notice. Montabert gives, and the brochure contains, no warranties whatsoever, express or implied. All the contents, including but not limited to text, images, graphics are all subject to copyright and all intellectual property protection. Their use or misuse is strictly prohibited. Montabert brand and logo used herein are the property of Montabert. Nothing contained on this document shall be construed as constituting any commitment by Montabert or as granting any license or right to use any intellectual property. ©2024 Montabert. All rights reserved.

montabert.com

*see warranty conditions





HYDRAULIC ROCK BREAKER

SD42



NEW KEY ASSET
FOR ALL JOBSITES

DESIGNED FOR 5 TO
12 TONS CARRIERS

POWERFUL,
SAFE AND COMPACT

LANDSCAPING, DEMOLITION,
TRENCHING, CIVIL ENGINEERING,
INSIDE AND OUTSIDE:
VERSATILE AND EFFICIENT

BENEFITS

- **Hydraulic accumulator:** no more regular nitrogen controls and recharges on jobsites.
- **Tie rod free:** less weight and cost, more power and reliability.
- **Made in France:** superior quality steel and manufacturing excellence.
- **Improved soundproofing :** lower noise levels for urban jobsites.
- **Easy handling:** two lifting points to handle the breaker with perfect balance and safety, also acting as hoses protection.
- **Tool changing:** new user friendly, simple, safe and reliable system, with one single retainer.



HYDRAULIC ROCK BREAKER

NEW KEY ASSET FOR ALL JOBSITES

WEIGHT & DIMENSIONS

WEIGHT (KG/LB)

BREAKER	331	730
+ MOUNTED TOOL	364.7	804
+ MOUNTED ADAPTER PLATE (MAX)	456	1,005

DIMENSIONS (MM/IN)

A	1,494	59
B	442	17
C	556	22
D	1,059	42
E	270	11
F	295	12
G	48	2

OPERATING INFORMATION

CARRIER WEIGHT RANGE (MIN-MAX, MT)	5 - 12
OIL FLOW (MIN-MAX, L/MIN / GPM)	70 - 120 / 18.5 - 32
OPERATING PRESSURE (MAX, BAR/PSI)	125 / 1,815
BACK PRESSURE (MAX, BAR/PSI)	20 / 290
INPUT POWER (KW)	25
STRIKING FREQUENCY (MIN-MAX, BPM)	700 - 1,440
NOISE LEVEL /10M (DBA)	93
SOUNDPROOFING	standard
HOSE PROTECTION	standard

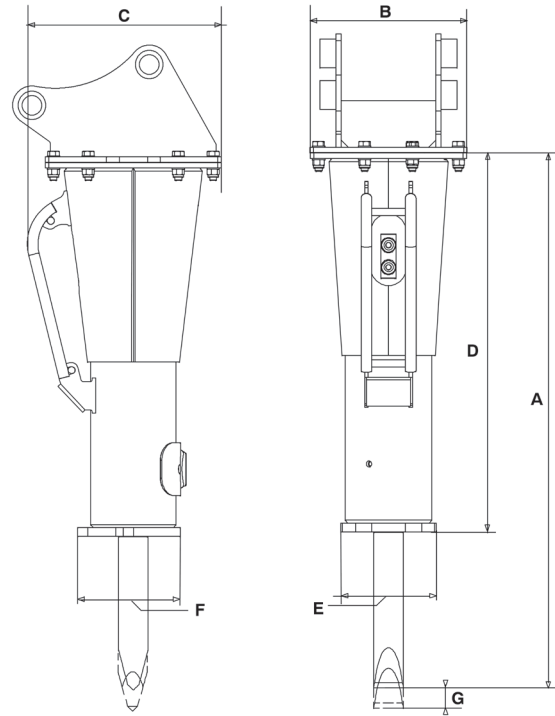

OPTIONS

OPTIONS	PART NUMBER
ADAPTER PLATE	upon request
SPECIAL PAINTING	upon request

CONSUMABLES

GREASE CARTRIDGES (X48)

PART NUMBER

86799152

MAINTENANCE KITS

LEVEL	PART NUMBER
LEVEL 1	101112797
LEVEL 2	101112798
LEVEL 3 (+2 WARRANTY YEARS*)	101112799

TOOLS

DIAMETER (MM/IN)	84 / 3.3	84 / 3.3	84 / 3.3
LENGTH (MM/IN)	785 / 31	785 / 31	785 / 31
WEIGHT (KG/LB)	32 / 71	32 / 71	34 / 75
PART NUMBER	86665338	86665361	86685047



The content of this brochure constitutes non-binding information and may be changed at any time without notice. Montabert gives, and the brochure contains, no warranties whatsoever, express or implied. All the contents, including but not limited to text, images, graphics are all subject to copyright and all intellectual property protection. Their use or misuse is strictly prohibited. Montabert brand and logo used herein are the property of Montabert. Nothing contained on this document shall be construed as constituting any commitment by Montabert or as granting any license or right to use any intellectual property. ©2024 Montabert. All rights reserved.

montabert.com

*see warranty conditions

