



HYDRAULIC ROCK BREAKER
V2500



POWER AND
VERSATILITY
FOR ALL JOBSITES

DESIGNED FOR 27 TO
40 TONS CARRIERS

MAXIMUM IMPACT FORCE SINCE
THE VERY FIRST BLOW

A TOOL WHICH FITTED
FOR ANY SITUATION

4.0 BREAKER

BENEFITS

- **Hydraulic accumulator:** no more regular nitrogen controls and recharges on jobsites.
- **Automatic lubrication:** cartridge grease pump mounted on breaker, or tank mounted on excavator.
- **Made in France:** superior quality steel and manufacturing excellence.
- **Dynamic energy adjustment:** two working positions automatically adjusted by the breaker.
- **Blank firing protection:** increased wear parts lifespan.



HYDRAULIC ROCK BREAKER

POWER AND VERSATILITY
FOR ALL JOBSITES

WEIGHT & DIMENSIONS

WEIGHT (KG/LB)

BREAKER	2,185	4,817
+ MOUNTED TOOL	2,390	5,269
+ MOUNTED ADAPTER PLATE (MAX)	2,866	6,318

DIMENSIONS (MM/IN)

A	2,124	83.6
B	585	23.03
C	575	23
D	463	18.22
E	100	3.93

OPERATING INFORMATION

CARRIER WEIGHT RANGE (MIN-MAX, MT)	27 - 40
OIL FLOW (MIN-MAX, L/MIN / GPM)	185 - 250 46.3 - 66.1
MAXIMUM OPERATING PRESSURE (BAR/PSI)	155 2,248
MAXIMUM BACK PRESSURE (BAR/PSI)	25 363
INPUT POWER (KW)	64.6
STRIKING FREQUENCY (MIN-MAX, BPM)	320 - 560
NOISE LEVEL /10M (DBA)	92
AUTOMATIC LUBRICATION	standard
SOUNDPROOFING	standard
INSPECTION KIT	standard
PRESSURIZATION	preinstalled
OMNI-M Monitoring system	standard

OPTIONS

PART NUMBER

PRESSURIZATION KIT	86372505
SOFTSTART	86778792
ADAPTER PLATE	upon request
SPECIAL PAINTING	upon request

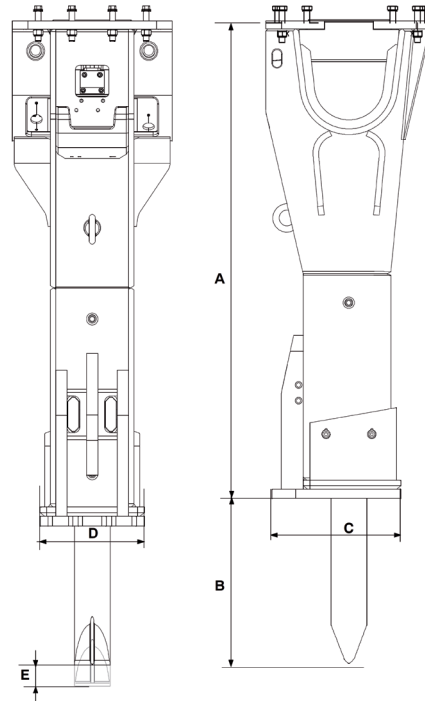

CONSUMABLES

PART NUMBER

GREASE CARTRIDGES (X20)	86784758
ABL2 GREASE BUCKET (18 KG)	101095009
ABLF GREASE BUCKET (18 KG)	101095008

MAINTENANCE KITS

PART NUMBER

BASIC	101187545
INTERMEDIATE	101187546
ADVANCED	101187547
DEDICATED TIE RODS KIT	101187548

TOOLS

DIAMETER (MM/IN)	160 / 6.29	160 / 6.29	160 / 6.29
LENGTH (MM/IN)	1,350 / 53	1,350 / 53	1,350 / 53
WEIGHT (KG/LB)	194 / 428	195 / 430	205 / 452
PART NUMBER	86780046	86780038	86780053



The content of this brochure constitutes non-binding information and may be changed at any time without notice. Montabert gives, and the brochure contains, no warranties whatsoever, express or implied. All the contents, including but not limited to text, images, graphics are all subject to copyright and all intellectual property protection. Their use or misuse is strictly prohibited. Montabert brand and logo used herein are the property of Montabert. Nothing contained on this document shall be construed as constituting any commitment by Montabert or as granting any license or right to use any intellectual property. ©2024 Montabert. All rights reserved.

montabert.com

