



HYDRAULIC ROCK BREAKER

V47



CUTTING-EDGE
TECHNOLOGY
RUTHLESS FOR ROCKS

DESIGNED FOR 27 TO
40 TONS CARRIERS

AUTOMATIC ENERGY PER
BLOW ADJUSTMENT

AUTONOMOUS WORKING
PRESSURE CONTROL

4.0 BREAKER

BENEFITS

- **Hydraulic accumulator:** no more regular nitrogen controls and recharges on jobsites.
- **Made in France:** superior quality steel and manufacturing excellence.
- **Operator friendly:** blank firing protection, automatic lubrication, energy recovery system, easy maintenance.
- **Carrier friendly:** anti-vibration dampeners, pressure spikes removal.
- **TPS system:** improved tool lifespan



HYDRAULIC ROCK BREAKER

CUTTING-EDGE TECHNOLOGY RUTHLESS FOR ROCKS

WEIGHT & DIMENSIONS

WEIGHT (KG/LB)

BREAKER	2,080	4,586
+ MOUNTED TOOL	2,273	5,011
+ MOUNTED ADAPTER PLATE (MAX)	2,745	6,061

DIMENSIONS (MM/IN)

A	2,075	81.7
B	715	28.1
C	700	27.5
D	803	31.6
E	450	17.7
F	590	23.3
G	60	2.3

OPERATING INFORMATION

CARRIER WEIGHT RANGE (MIN-MAX, MT)	27 - 40
OIL FLOW (MIN-MAX, L/MIN / GPM)	180 - 265 47.6 - 70
OPERATING PRESSURE (BAR/PSI)	165 2,393
BACK PRESSURE (BAR/PSI)	12 174
INPUT POWER (KW)	72.9
STRIKING FREQUENCY (BPM)	345 - 1,160
NOISE LEVEL /10M (DBA)	96
AUTOMATIC LUBRICATION	standard
SOUNDPROOFING	standard
PRESSURIZATION	preinstalled
OMNI-M MONITORING SYSTEM	standard

OPTIONS

PART NUMBER

PRESSURIZATION KIT	86372505
TUNNELING KIT	upon request
DUST SUPPRESSION KIT	upon request
ADAPTER PLATE	upon request
SPECIAL PAINTING	upon request

TOOLS

DIAMETER (MM/IN)	150 / 5.9	150 / 5.9	150 / 5.9	150 / 5.9	150 / 5.9
LENGTH (MM/IN)	1,350 / 53.14	1,500 / 59.05	1,350 / 53.14	1,500 / 59.05	1,350 / 53.14
WEIGHT (KG/LB)	170 / 375	191 / 421	172 / 379	193 / 425	180 / 387
PART NUMBER	86492246	86593522	86608130	86604931	86492253

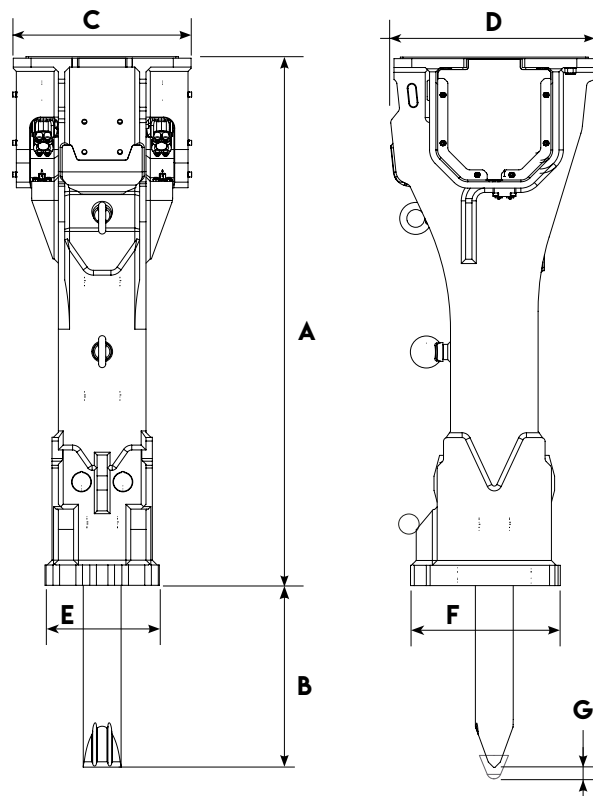

CONSUMABLES

PART NUMBER

GREASE CARTRIDGES (X20)	86784758
ABL2 GREASE BUCKET (18 KG)	101095009
ABLF GREASE BUCKET (18 KG)	101095008

MAINTENANCE KITS

PART NUMBER

BASIC	101189823
INTERMEDIATE	101189834
ADVANCED	101189835
DEDICATED TIE RODS KIT	101188049



The content of this brochure constitutes non-binding information and may be changed at any time without notice. Montabert gives, and the brochure contains, no warranties whatsoever, express or implied. All the contents, including but not limited to text, images, graphics are all subject to copyright and all intellectual property protection. Their use or misuse is strictly prohibited. Montabert brand and logo used herein are the property of Montabert. Nothing contained on this document shall be construed as constituting any commitment by Montabert or as granting any license or right to use any intellectual property. ©2024 Montabert. All rights reserved.

montabert.com

